

PARÇA KODU PART CODE	PARÇA ADI PART NAME	s ÖLÇÜSÜ (KALINLIK) s MEASURE (THICKNESS)	Malzeme Material	Kaplama Coating
TŞ 2488.60 DP	2.5 NO 2.TERMİNAL Ø4.3 =DP=	0.60±0.05	(CuZn30) Pirinç / Brass	—
TŞ 2488.60 RP	2.5 NO 2.TERMİNAL Ø4.3 =RP=	0.60±0.05	(CuZn30) Pirinç / Brass	—
TŞ 2488.60 RPK	2.5 NO 2.TERMİNAL Ø4.3 =RPK=	0.60±0.05	(CuZn30) Pirinç / Brass	Kalay / Sn (3-5µ)
TŞ 2488.60 DPK	2.5 NO 2.TERMİNAL Ø4.3 =DPK=	0.60±0.05	(CuZn30) Pirinç / Brass	Kalay / Sn (3-5µ)
TŞ 2488.80 DP	2.5 NO 2.TERMİNAL Ø4.3 =DP=	0.80±0.05	(CuZn30) Pirinç / Brass	—
TŞ 2488.80 RP	2.5 NO 2.TERMİNAL Ø4.3 =RP=	0.80±0.05	(CuZn30) Pirinç / Brass	—
TŞ 2488.80 RPK	2.5 NO 2.TERMİNAL Ø4.3 =RPK=	0.80±0.05	(CuZn30) Pirinç / Brass	Kalay / Sn (3-5µ)
TŞ 2488.80 DPK	2.5 NO 2.TERMİNAL Ø4.3 =DPK=	0.80±0.05	(CuZn30) Pirinç / Brass	Kalay / Sn (3-5µ)

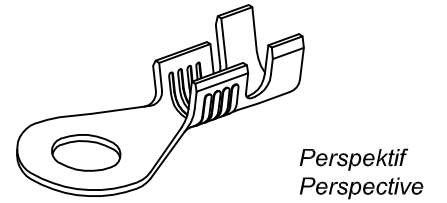
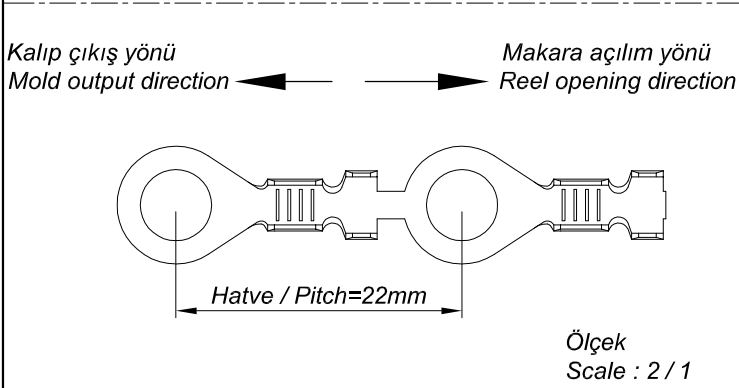
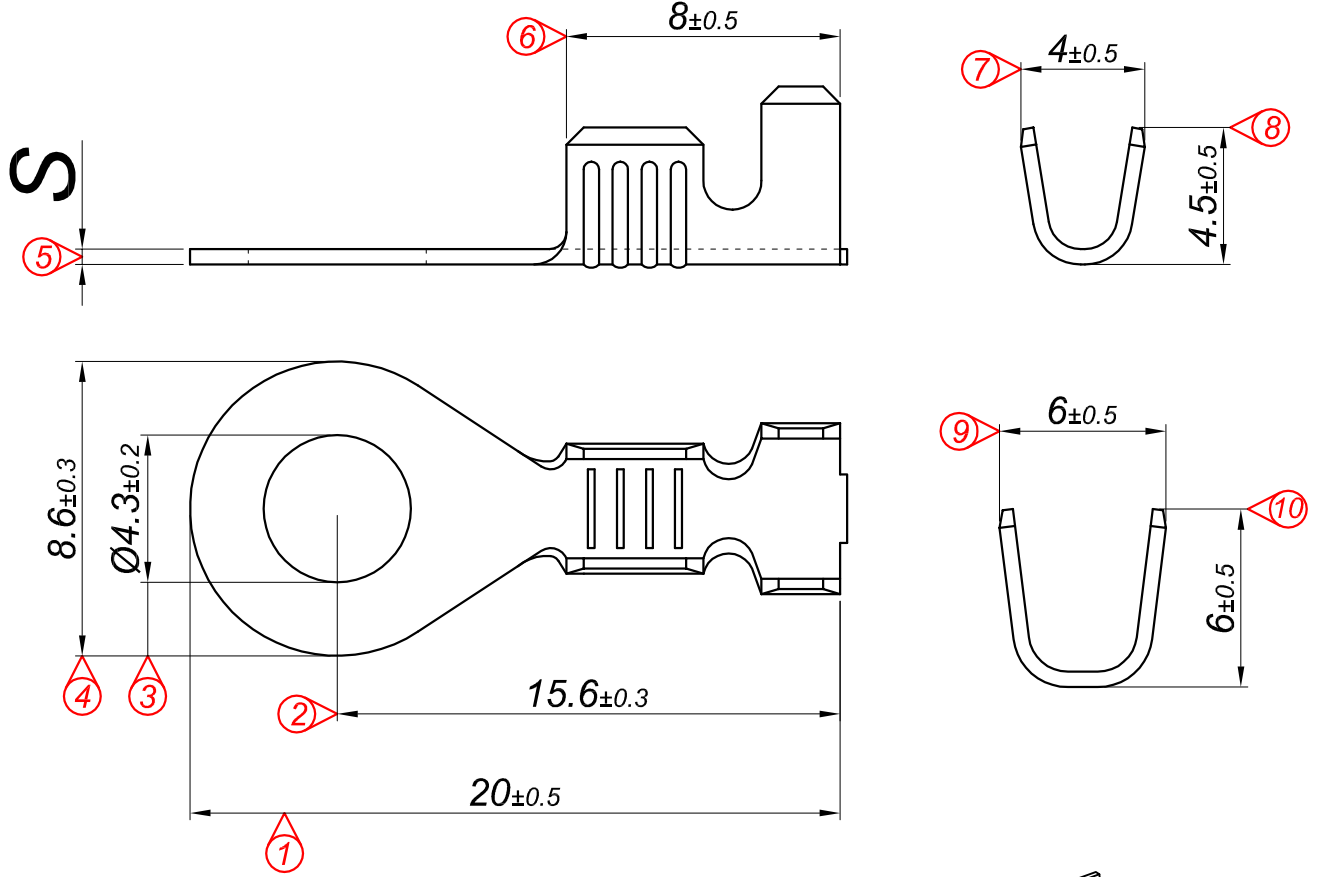

**Kablo Kesiti**  
**Wire Section : 1 - 2.50 mm<sup>2</sup>**

Resim üzerinden ölçü almayınız  
do not measure on drawing

Tarih / Date	18.05.2016	İmza /Signature	Ölçek /Scale		
Çizen / Desing	T.Topçu				
Onay / Approval	S.Gölcük		5 / 1	No	Değişiklik / Revision
					Tarih/Date
	Parça Adı: Part Name	2.5 NO 2.TERMİNAL Ø4.3		Parça Kodu: Part Code	TŞ 2488